

- 20) Using two mounting bolts (Item 6), install the servo (Item 7) to top rear of the charchol canister.
- 21) Install servo assembly vacuum supply to the capped port on the tee fitting located on top rear of the intake manifold.
- 22) Check engine compartment harness in the area where the servo mounts for an open 4-way connector. If connector is not found, the servo overlay harness (Item 8) must be installed (see Step 27).

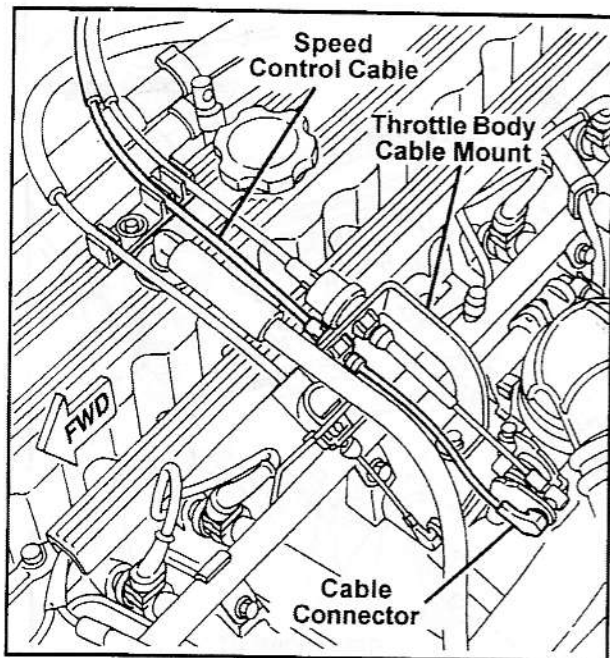

- 23) Route speed control cable across top of bulkhead close to engine compartment harness.
- 24) Route cable connector thru open hole in the throttle body cable mount.
- 25) Snap cable clip onto throttle body cable mount.
- 26) Snap cable connector to the front side of throttle body bell crank pin.

### **CAUTION !**

*Check to see that the throttle opens and closes without binding.*

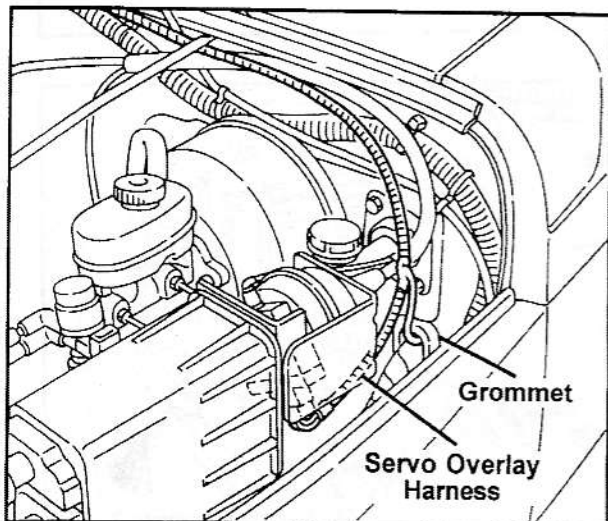

### **SERVO OVERLAY HARNESS INSTALL**

- 27) Lay the harness across main bulkhead harness in the engine compartment.
- 28) Plug 4-way connector from the servo overlay harness (Item 8) into the servo.
- 29) Make a 1/4" hole in the grommet located where the main harness passes thru the bulkhead.
- 30) Rig-up a pull tab and taking care not to bend the terminals, feed six terminated wires from the servo overlay harness thru hole.